

Q5

Gang Type CNC Lathe

Item	Specification	Unit	Q5
Turning capacity	Max. swing diameter	mm	Ø230
	Max. swing diameter over saddle	mm	-
	Max. turning diameter	mm	Ø50
	Max. turning length	mm	40
Spindle	Spindle nose		A2-4
	Spindle speed	rpm	6,000 (Opt. 8,000)
	Chuck O.D.	inch	5" (Opt. 4" pneumatic chuck)
	Through-spindle hole diameter	mm	Ø35
	Bar capacity	mm	Ø26
	Spindle bearing diameter	mm	Ø70
Turret	Tool capacity	pc	4~6 (Depend on workpiece)
	O.D. tool	mm	16×16
	I.D. tool	mm	Ø20
Stroke	X/Z axis stroke	mm	220/220
Feed	X/Z axis rapid traverse	m/min	30/30
	Cutting feedrate	mm/rev	0.001-5000
Hydraulic unit	Hydraulic tank capacity	L	12
	Hydraulic motor	kW	0.75
Coolant unit	Coolant tank capacity	L	90
	Coolant motor	kW	0.18
Motor	Spindle motor	kW	5.5/3.7
	X/Z axis servo motor	kW	0.75/0.75
Machine size	L×W×H	mm	1,490×1,870×1,610
	Weight	kg	1,500

Machine dimensions

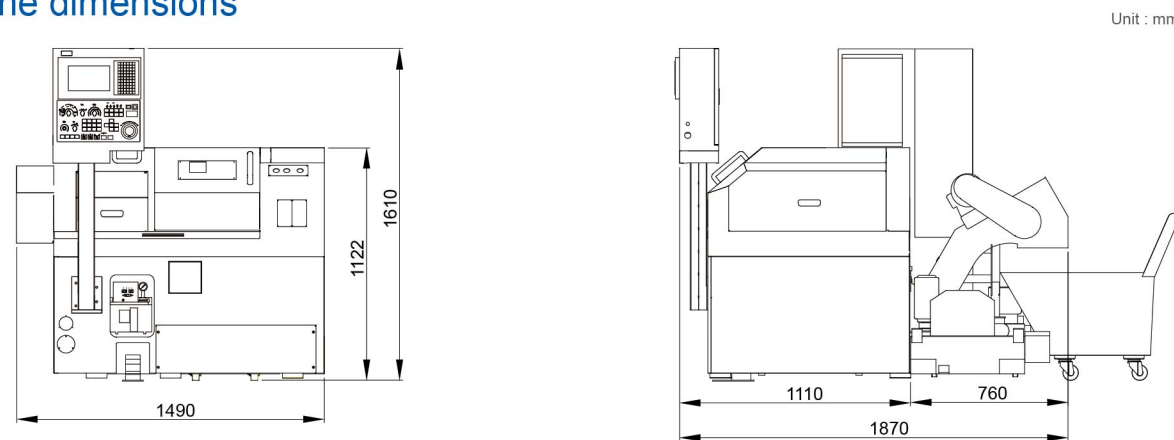

Spindle output and torque chart

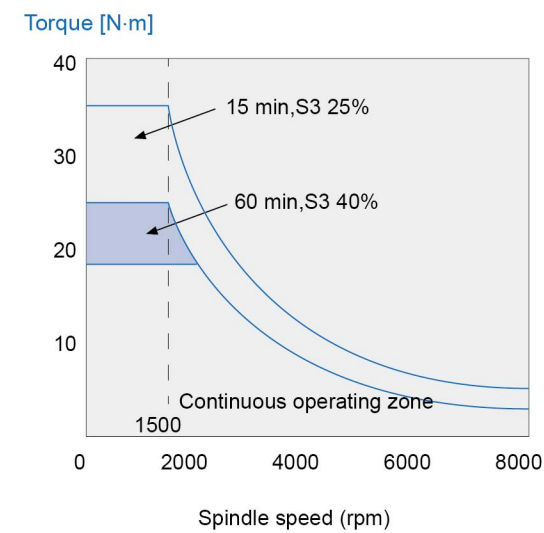
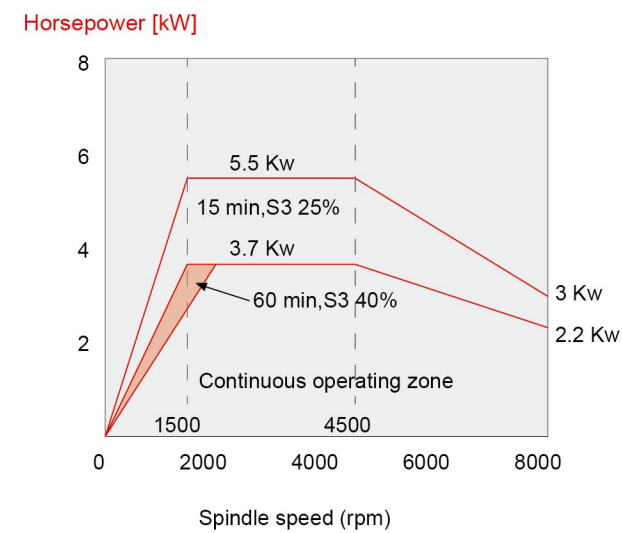

Tongtai Tongtai Machine & Tool Co., Ltd.

NO.3, LUKE 3rd. RD., LUZHU DISTRICT, KAOHSIUNG CITY, 82151, TAIWAN.
 TEL : 886-7-9761588
 FAX : 886-7-9761589/886-7-9761590
 Website : <http://www.tongtai.com.tw>

Taoyuan Office	TEL : 886-3-4551399	FAX : 886-3-4559730
Taichung Office	TEL : 886-4-23589600	FAX : 886-4-23589993
Tongtai Seiki U.S.A Inc.	TEL : 1-845-2675500	FAX : 1-845-2675546
Tongtai Machine & Tool Japan Co., Ltd	TEL : 81-4-71438355	FAX : 81-4-71438360
Tongtai Seiki Vietnam Limited	TEL : 84-435112529	
Europe Office	TEL : 31-161-454639	FAX : 31-161-454768
Thailand Office	TEL : 66-2-7443440	FAX : 66-2-3986518
Indonesia Office	TEL : 62-21-45850521	FAX : 62-21-45840522
Malaysia Office	TEL : 60-3-78456815	FAX : 60-3-78456851



SHUZHOU TONG-YU MACHINE & TOOL CO., LTD.
 TEL : 86-512-63430168
 FAX : 86-512-63431622
 E-mail : sales@tong-yu.com.cn

Wuhan Office	TEL : 86-27-59409109	FAX : 86-27-59409110
Shanghai Office	TEL : 86-21-24208138	FAX : 86-21-34073262
Chongqing Office	TEL : 86-23-67865925	FAX : 86-23-67867717
Shenzhen Office	TEL : 86-755-27222119	FAX : 86-755-27222115
Tianjin Office	TEL : 86-22-24417640	FAX : 86-22-24416738
Shenyang Office	TEL : 86-24-24142968	FAX : 86-24-24115782



Q5

- Compact floor space
- Stable high quality machining precision
- Suitable for mass production
- High cost-performance value

Turning accuracy

		Roundness	Roughness
Material	Copper	0.42μm	0.85μm
Spindle speed	3,000 rpm		
Freedrate	0.01 mm/rev		

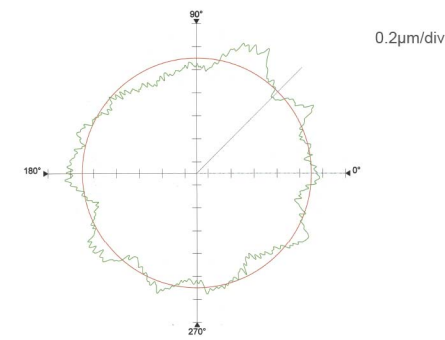

Travel

X/Z axis travel	220 mm
X/Z axis rapid travel	30 m/min
Spindle speed	6,000 rpm
	8,000 rpm (Opt.)

Tool system

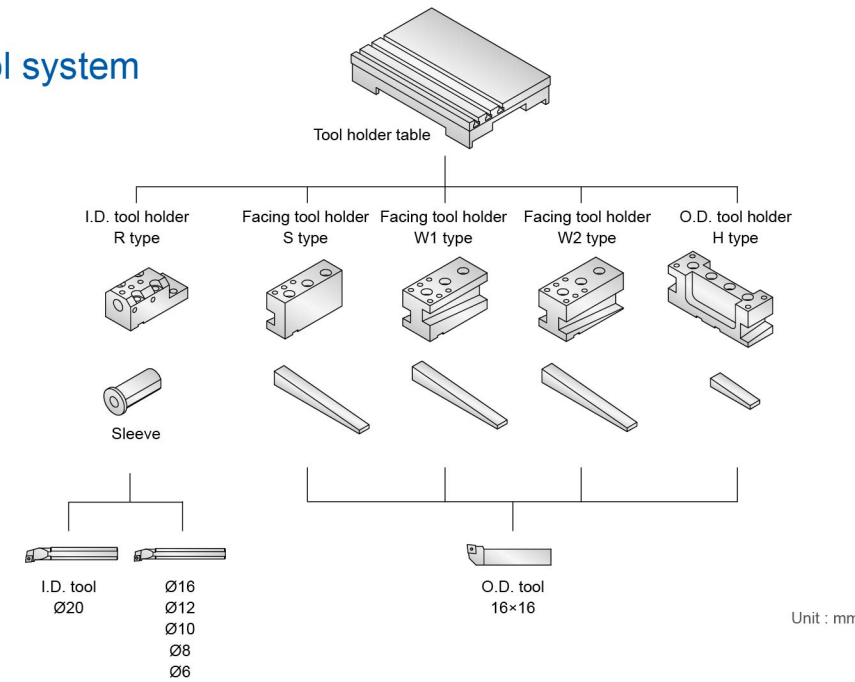

8 rotary pallets stocker

Workpiece diameter : $\varnothing 5$ - $\varnothing 50$ mm
 Max. workpiece length : 40 mm
 Max. workpiece weight : 0.6 kg \times 2
 Rapid traverse of robot : 90 m/min

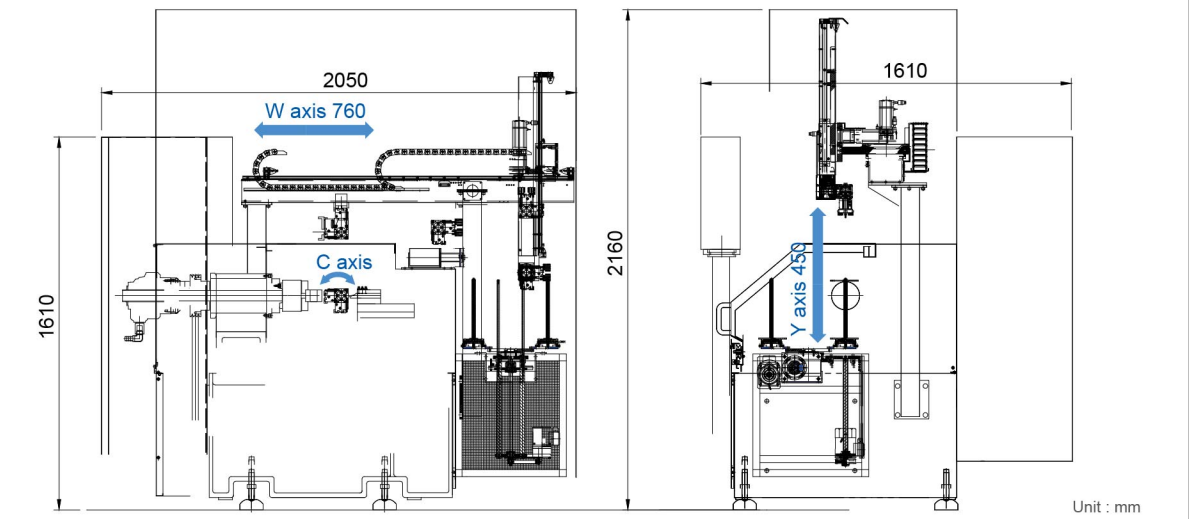

Automation Solutions :

- Solution 1** Bar feeder type
 Bar feeder with part catcher and part conveyor are used. The structure is simple and easy to operate.
- Solution 2** Gantry loader type
 Combination with stocker and gantry loader, the machine is able to achieve the goal of automatic production to minimize labor costs and maximize investment returns.

Gantry loader & Stocker

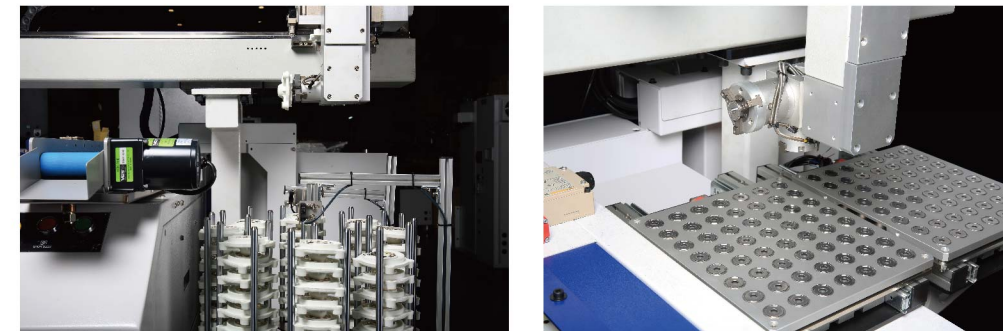

Gantry loader adopts high volume stocker allows long-term automatic management and improves the machine value.

Depend on different kinds of workpiece, we are able to provide you the best workpiece stock solution.

Bar feeder & Part catcher & Part Conveyor



Tool zone

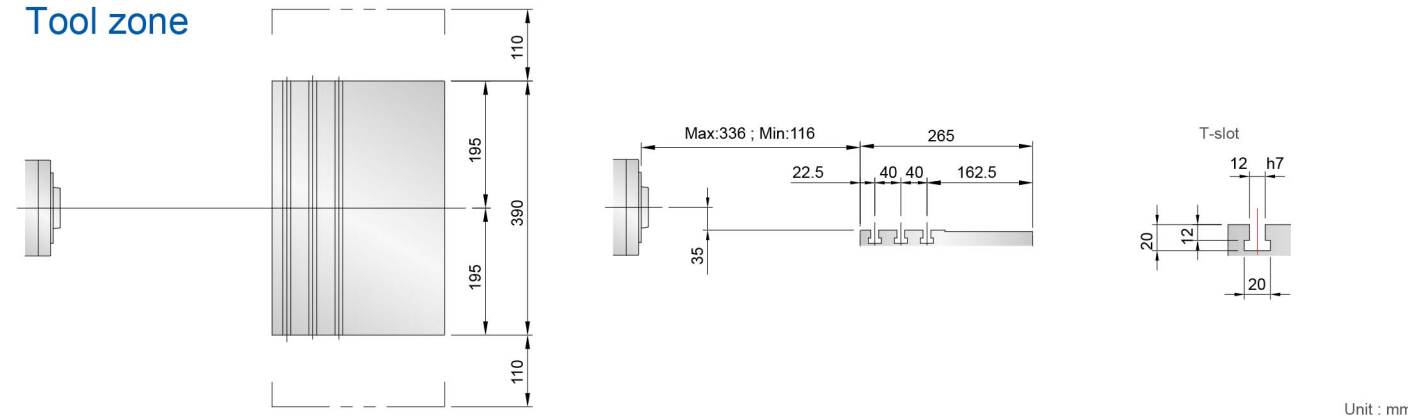

2 pallets stocker

Workpiece diameter : $\varnothing 5$ - $\varnothing 50$ mm
 Max. workpiece length : 40 mm
 Max. workpiece weight : 0.6 kg \times 2
 Rapid traverse of robot : 90 m/min

